

# The Devon Community Directory as an example of web application development with eXist

Adam Retter  
Principal Developer  
Devon Portal Project  
adam.retter@devon.gov.uk  
+44 (0)1392 383683

## What is the Devon Portal Project?

- A Partnership project between 11 Local Government Authorities, Fire, Police and Dartmoor National Park in Devon, UK. Branded as devonline
- A vehicle for the electronic delivery of joined-up services by innovative IT solutions
- e.g. A Devon wide Search and A-Z, see <http://www.devonline.gov.uk>



## What is the Devon Community Directory?

- One of our Partnership Projects
- A directory of Community Groups in Devon, will include approximately 10,000 records when it launches in September 2006
- A community information Search and Display mechanism for the Public
- A system enabling staff to maintain and validate the correctness of Information about groups
- An amalgamation of existing databases of information and disparate systems. At least 8 separate Community Group databases were identified within Devon County Council alone. Meets UK e-Government Priority Outcome

## Why we chose eXist?

- Poor project specification, therefore flexibility was required in the design and development stages. Relational DB and typical Web Application development (e.g. MySQL+PHP) was deemed too strict. XML offered a much more flexible and easily extendable route; fitted well with our evolutionary development model.
- We wanted to use Open Source software to reduce risks as many decisions were still outstanding
- An evaluation of eXist showed it to be the most complete XML DB suite in its class; Technically Complete / Very well supported by its developers and users / Easy to get started with / Allowed for rapid development.

## Our eXist Web Application -

- 94% pure XQuery goodness, 4% XSLT, 1% JavaScript and CSS, 1% Java
- All application resources are stored in the eXist DB, including – XQuery, XSLT, Schema, JavaScript, CSS, Images, JAR Files. And of course the XML Data.
- All business processes are Written in XQuery (apart from a small Java Applet to launch a word processor)
- The presentation layer is XSLT, rendering XML generated from the XQuery to XHTML coupled with CSS for presentation in a web browser. This allows easy replacement or modification of the GUI.

## Community Directory Architecture

- Browser makes a HTTP request for a XQuery script stored in the DB
- XQuery is executed and performs actions on XML documents etc.
- XSLT renders XML to XHTML for the browser
- Browser uses HTTP to request images and JavaScript referenced by the XHTML from the eXist DB

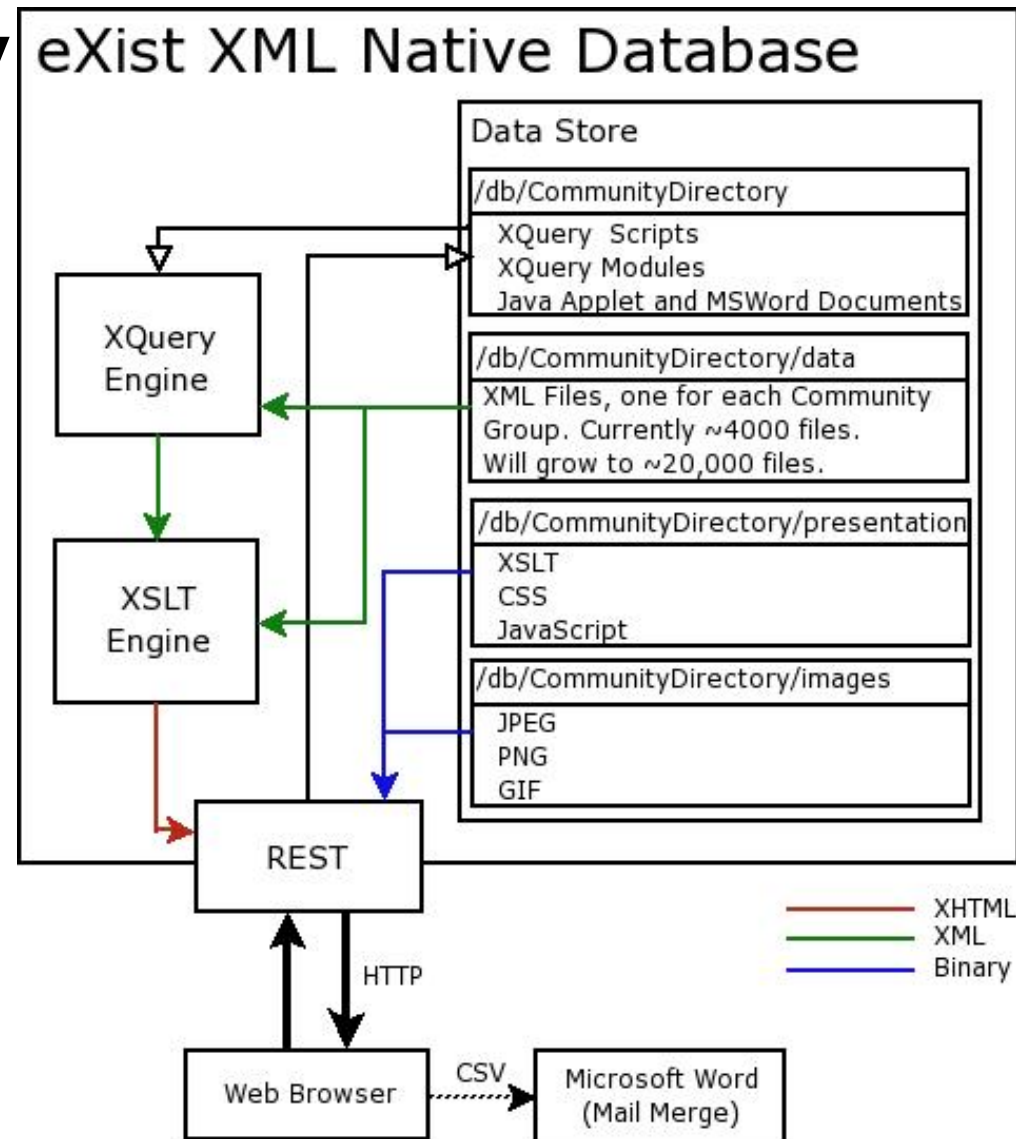

## Items of Interest

- Authentication is done using eXist users, Session and some meta-data (simply stored in an XML file in the DB)
- eXist's Range Indexes feature has been used to speed up complex XQueries
- eXist's XQuery update extensions have been used to process the output of HTML forms and create or modify Community Groups. (More flexible than XUpdate)
- We developed a mail extension module for eXist that allows email notifications to be sent to our users. Modules are easy to develop and we have contributed ours back to eXist :-)

## Problems/Solutions

- Slow XQueries: Range Indexes, QName Indexes, manual optimisation of XQuery code.
- Bug's or surprising results: Excellent mailing list and developer support through IRC. Or jump in yourself (its Open Source after all) - other developers/users can provide guidance. For us eXist support has been better than any commercial support contracts we have for other enterprise products.
- Design: Functionally XQuery and eXist are not that different to any other environment. Sometimes you just need to think things through properly first. Make use of reusable code and XQuery Modules and create well defined interfaces (XML -> XQuery -> XML -> XSLT)